

## Flat Cup-shaped vacuum cups

Diameter 85 mm, with or without support, rubber

### MATERIAL

Vacuum cup in oil-proof rubber (NBR), natural (NR), or silicone (VMQ).

Support in nickel-plated brass or anodised aluminium.

### STANDARD EXECUTIONS

- **VVI-85-A**: oil-proof rubber, without support.
- **VVI-85-N**: natural rubber, without support.
- **VVI-85-S**: silicone rubber, without support.
- **VVI-85-T-A**: oil-proof rubber, with support.
- **VVI-85-T-N**: natural rubber, with support.
- **VVI-85-T-S**: silicone rubber, with support.

### FEATURES AND APPLICATIONS

Vacuum suction cups with a G 1/4" threaded support have an M8 threaded hole inside to allow for the possible insertion of a grub screw with a calibrated hole.

This allows the suction section of the vacuum suction cup to be reduced, thus reducing the vacuum losses that could be generated if the vacuum suction cup fails to grip the surface of the product.

They are specifically used for handling ceramic or concrete tiles with smooth or shaped surfaces and, in general, for handling products with very different technical characteristics in terms of size, materials, form, and gripping surfaces (flat, slightly convex or concave).

See Technical Data for vacuum cups (on page -).

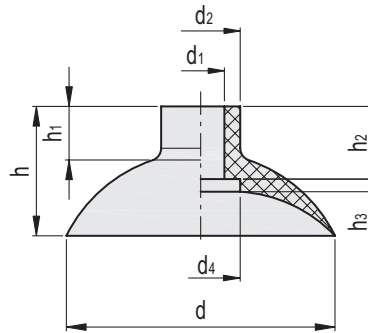

### VVI-85-A

Code	Description	d	d1	d2	d4	h	h1	h2	h3	F* [Kg]	Volume # [cm3]	⚖
VV.53031	VVI-85-A	85	15	25	25	41	16	23	4	14	54.8	36

### VVI-85-N

Code	Description	d	d1	d2	d4	h	h1	h2	h3	F* [Kg]	Volume # [cm3]	⚖
VV.53032	VVI-85-N	85	15	25	25	41	16	23	4	14	54.8	36

### VVI-85-S

Code	Description	d	d1	d2	d4	h	h1	h2	h3	F* [Kg]	Volume # [cm3]	⚖
VV.53033	VVI-85-S	85	15	25	25	41	16	23	4	14	54.8	36

\* The force of the vacuum cups indicated in the table represents 1/3 of the value of the theoretical force calculated at a vacuum level of -75 KPa and a safety coefficient of 3.

# Indicates the internal geometric volume of the vacuum cup and represents the volume to be added to the entire distribution circuit for the calculation of the evacuation time, especially if multiple vacuum cups are used.

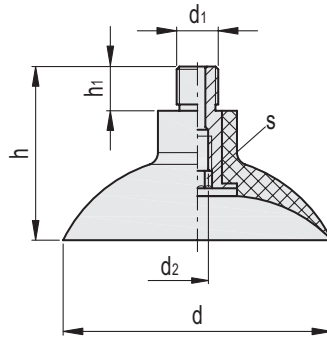

VVI-85-T-A

Code	Description	d	d <sub>1</sub>	d <sub>2</sub>	h	h <sub>1</sub>	s	F* [Kg]	Volume # [cm <sup>3</sup> ]	⚖️
VV.53034	VVI-85-G1/4-T-A	85	G1/4	M8	55	14	8	14	54.8	50
VV.54034	VVI-85-G1/8-T-A	85	G1/8	M8	55	14	8	14	54.8	46
VV.54037	VVI-85-M10x1.25-T-A	85	M10x1.25	M8	55	14	8	14	54.8	74

VVI-85-T-N

Code	Description	d	d <sub>1</sub>	d <sub>2</sub>	h	h <sub>1</sub>	s	F* [Kg]	Volume # [cm <sup>3</sup> ]	⚖️
VV.53035	VVI-85-G1/4-T-N	85	G1/4	M8	55	14	8	14	54.8	50
VV.54035	VVI-85-G1/8-T-N	85	G1/8	M8	55	14	8	14	54.8	46
VV.54038	VVI-85-M10x1.25-T-N	85	M10x1.25	M8	55	14	8	14	54.8	74

VVI-85-T-S

Code	Description	d	d <sub>1</sub>	d <sub>2</sub>	h	h <sub>1</sub>	s	F* [Kg]	Volume # [cm <sup>3</sup> ]	⚖️
VV.53036	VVI-85-G1/4-T-S	85	G1/4	M8	55	14	8	14	54.8	50
VV.54036	VVI-85-G1/8-T-S	85	G1/8	M8	55	14	8	14	54.8	46
VV.54039	VVI-85-M10x1.25-T-S	85	M10x1.25	M8	55	14	8	14	54.8	74

\* The force of the vacuum cups indicated in the table represents 1/3 of the value of the theoretical force calculated at a vacuum level of -75 KPa and a safety coefficient of 3.

# Indicates the internal geometric volume of the vacuum cup and represents the volume to be added to the entire distribution circuit for the calculation of the evacuation time, especially if multiple vacuum cups are used.

